

STATE WHEN ORDERING

FW = ..... mm  
 FH = ..... mm  
 COW = ..... mm  
 COH = ..... mm  
 CL = ..... mm

Surface treatment

- Silver anodized
- Special anodized .....
- RAL .....
- Special powder coating .....

Options see layers:

- Alternative F (concrete/brick)
- Alternative U (aluminium/steel)
- Threshold floor guide, L = 1,5FW+58
- TightSeal (floor level difference max. ± 3 mm)

Glass option see drw. 1009030

Glass code:  
 .....

Limitation

FW x FH = max. 10 m<sup>2</sup>

Installation

- Floor heating
- Other .....

Customer: \_\_\_\_\_  
 Door id: \_\_\_\_\_  
 Project No: \_\_\_\_\_

Ref: \_\_\_\_\_  
 Date: \_\_\_\_\_  
 Sign: \_\_\_\_\_

Automatic door system  
 ASSA ABLOY Slim Eco telescopic 4 Panel wall mounted bipart  
 Art. No. 1009392-4PB-15  
 ASSA ABLOY SL520

**ASSA ABLOY**

8.0 1009392-EI

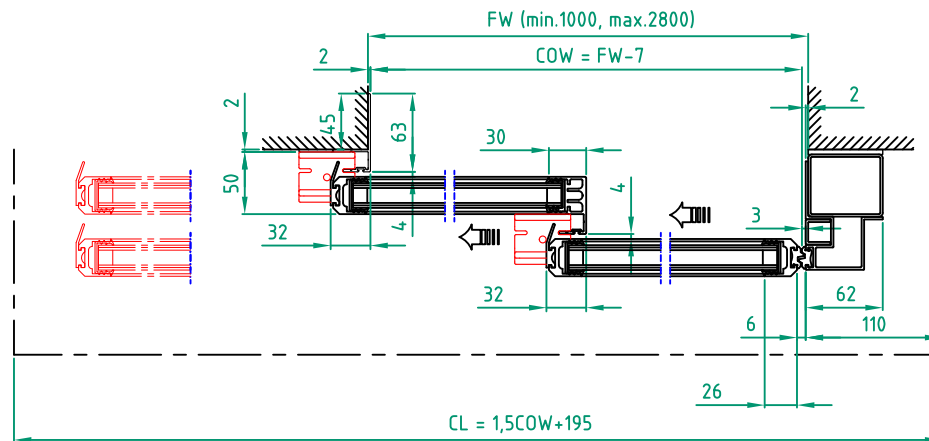
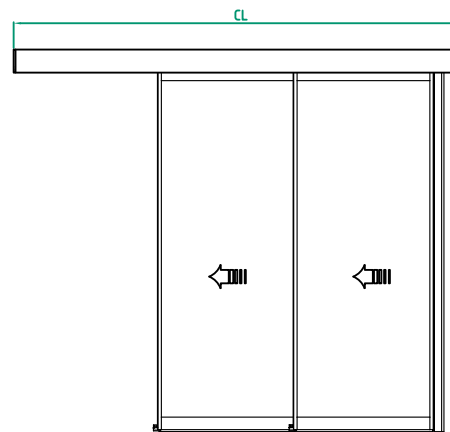
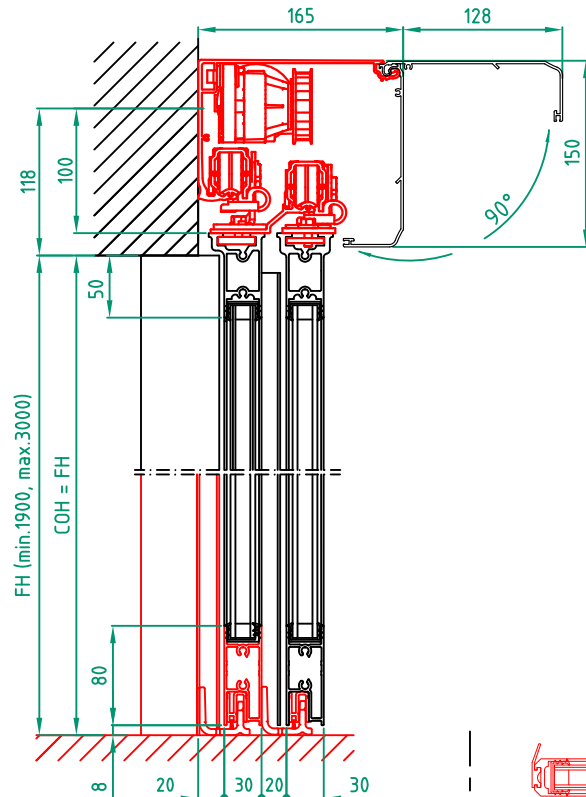

STATE WHEN ORDERING

FW = ..... mm  
 FH = ..... mm  
 COW = ..... mm  
 COH = ..... mm  
 CL = ..... mm

Surface treatment

- Silver anodized
- Special anodized .....
- RAL .....
- Special powder coating .....

Options see layers:

- Alternative F (concrete/brick)
- Alternative U (aluminium/steel)
- Threshold floor guide, L = 1,5FW+27
- TightSeal (floor level difference max. ± 3 mm)

Glass option see drw. 1009030

Glass code:

Limitation

FW x FH = max. 5,1 m<sup>2</sup>

Installation

- Floor heating
- Other .....

Customer:

Ref:

Door id:

Date:

Project No:

Sign:

Automatic door system  
 ASSA ABLOY Slim Eco telescopic  
 2 Panel wall mounted opening left, Art. No. 1009392-2PS-15  
 ASSA ABLOY SL520

**ASSA ABLOY**

8.0

1009392-EI

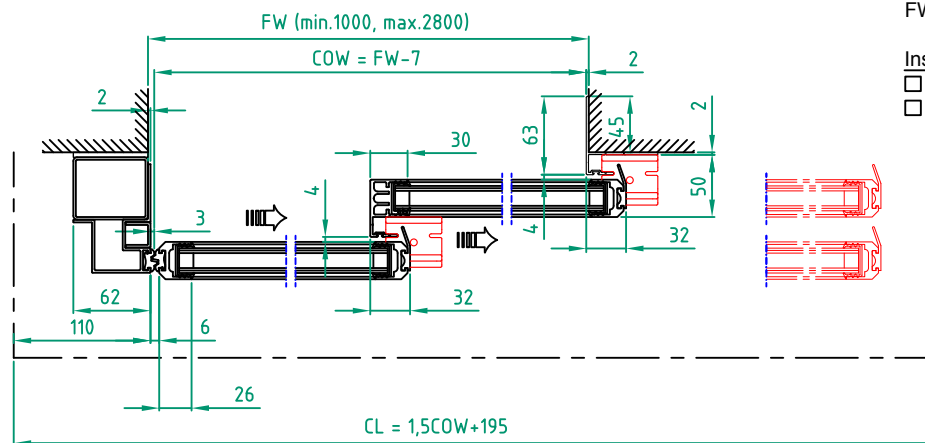
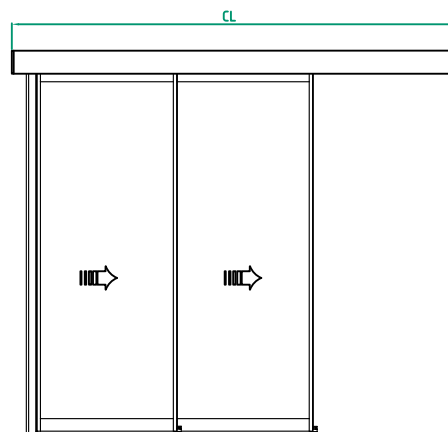
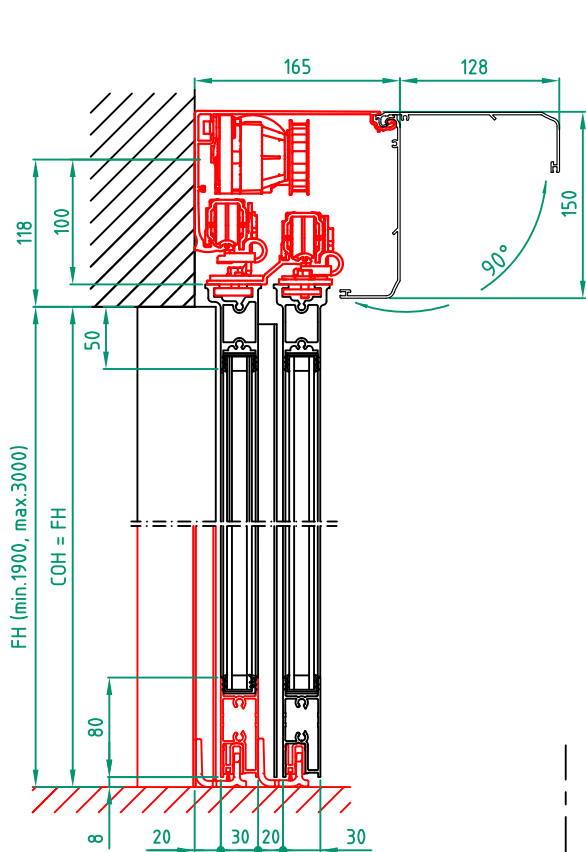

STATE WHEN ORDERING

FW = ..... mm  
 FH = ..... mm  
 COW = ..... mm  
 COH = ..... mm  
 CL = ..... mm

Surface treatment

Silver anodized  
 Special anodized .....  
 RAL .....  
 Special powder coating .....  
 .....

Options see layers:

- Alternative F (concrete/brick)
- Alternative U (aluminium/steel)
- Threshold floor guide, L = 1,5FW+27
- TightSeal (floor level difference max. ± 3 mm)

Glass option see drw. 1009030

Glass code:  
 .....

Limitation

FW x FH = max. 5,1 m<sup>2</sup>

Installation

- Floor heating
- Other .....

Customer:

Ref:

Door id:

Date:

Project No:

Sign:

Automatic door system  
 ASSA ABLOY Slim Eco telescopic  
 2 Panel wall mounted opening right, Art. No. 1009392-2PS-15  
 ASSA ABLOY SL520

**ASSA ABLOY**

8.0

1009392-EI

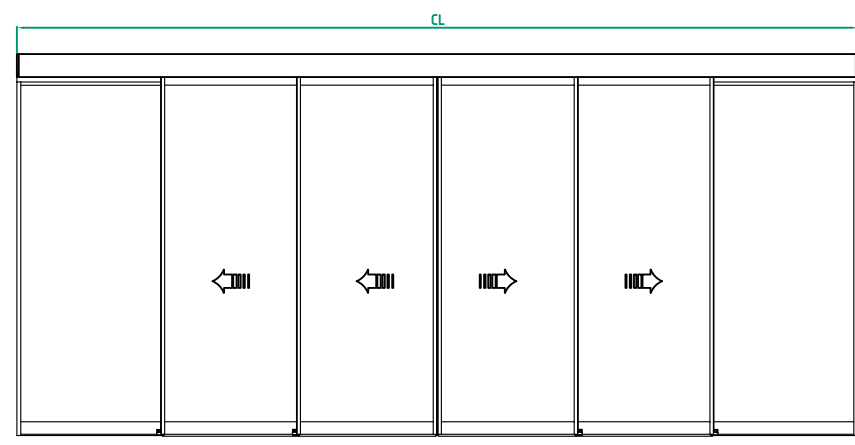
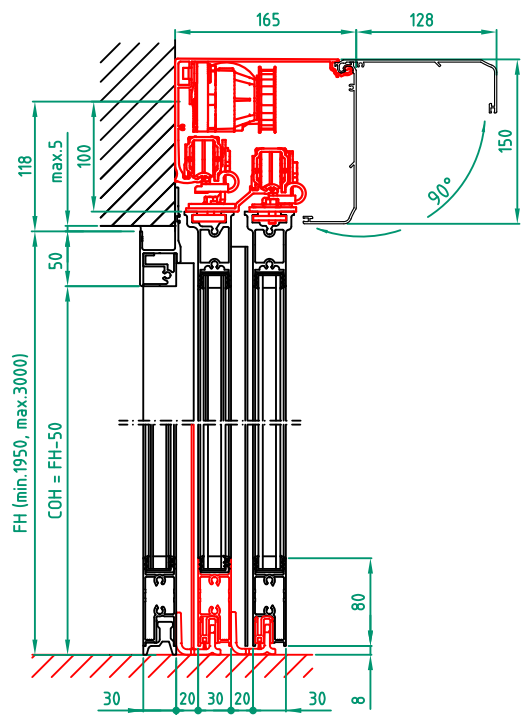

STATE WHEN ORDERING

- FW = ..... mm
- FH = ..... mm
- X = ..... mm
- COW = ..... mm
- COH = ..... mm
- CL = ..... mm

Surface treatment

- Silver anodized
- Special anodized .....
- RAL .....
- Special powder coating .....
- .....

Options see layers:

- Threshold floor guide, L = FW
- TightSeal (floor level difference max. ± 3 mm)

Glass option see drw. 1009030

Glass code: .....

Limitation

FW x FH = max. 15,6 m<sup>2</sup>

Installation

- Floor heating
- Other ..... min.5 max.10

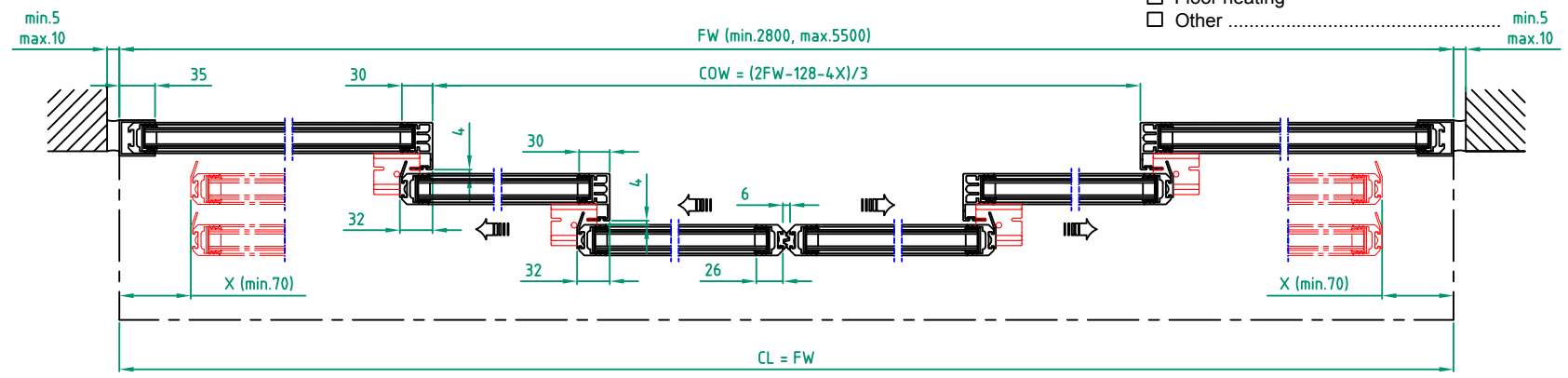

©ASSA ABLOY Entrance Systems AB, 2018  
Technical data subject to change without notice.

Customer: .....

Ref: .....

Door id: .....

Date: .....

Project No: .....

Sign: .....

Automatic door system  
 ASSA ABLOY Slim Eco telescopic 6 Panel wall mounted  
 Art. No. 1009392-6PB-15  
 ASSA ABLOY SL520

**ASSA ABLOY**

8.0

1009392-EI

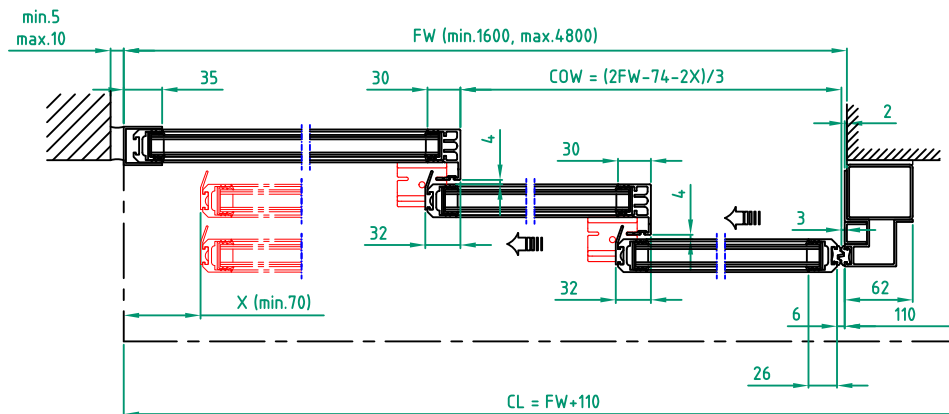
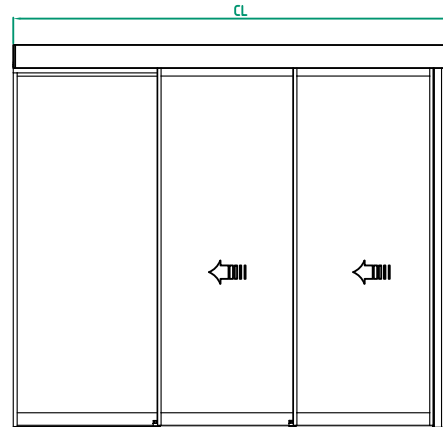
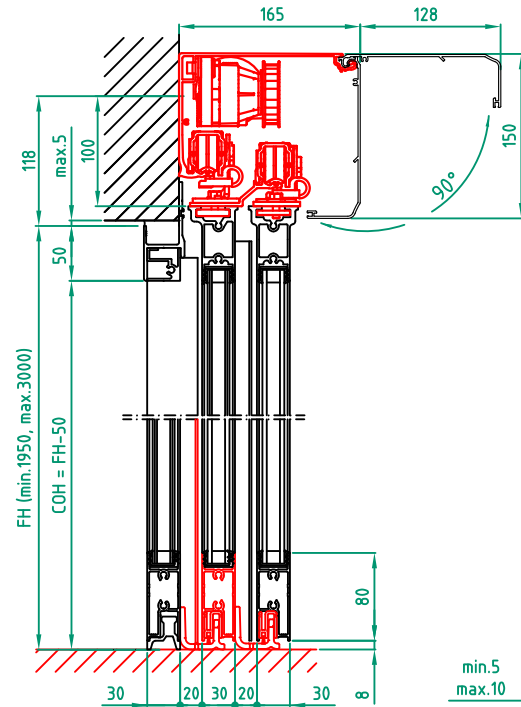

STATE WHEN ORDERING

FW = ..... mm  
 FH = ..... mm  
 X = ..... mm  
 COW = ..... mm  
 COH = ..... mm  
 CL = ..... mm

Surface treatment

- Silver anodized
- Special anodized .....
- RAL .....
- Special powder coating .....
- .....

Options see layers:

- Alternative F (concrete/brick)
- Alternative U (aluminium/steel)
- Threshold floor guide, L = FW
- TightSeal (floor level difference max. ± 3 mm)

Glass option see drw. 1009030

Glass code:

.....

Limitation

FW x FH = max. 7,8 m<sup>2</sup>

Installation

- Floor heating
- Other .....

Customer:

Ref:

Door id:

Date:

Project No:

Sign:

Automatic door system  
 ASSA ABLOY Slim Eco telescopic  
 3 Panel wall mounted opening left, Art. No. 1009392-3PS-15  
 ASSA ABLOY SL520

**ASSA ABLOY**

8.0 1009392-EI

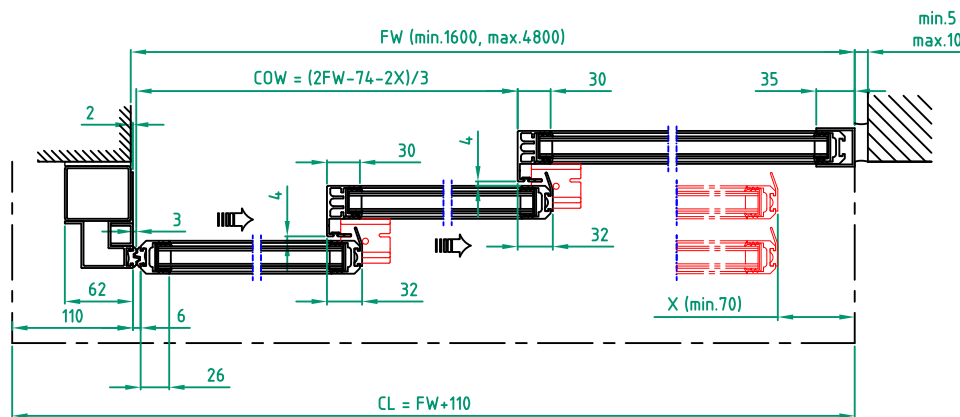
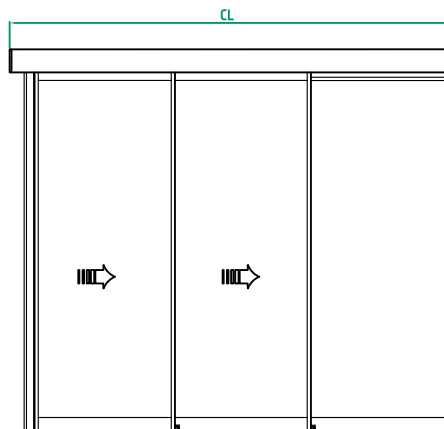
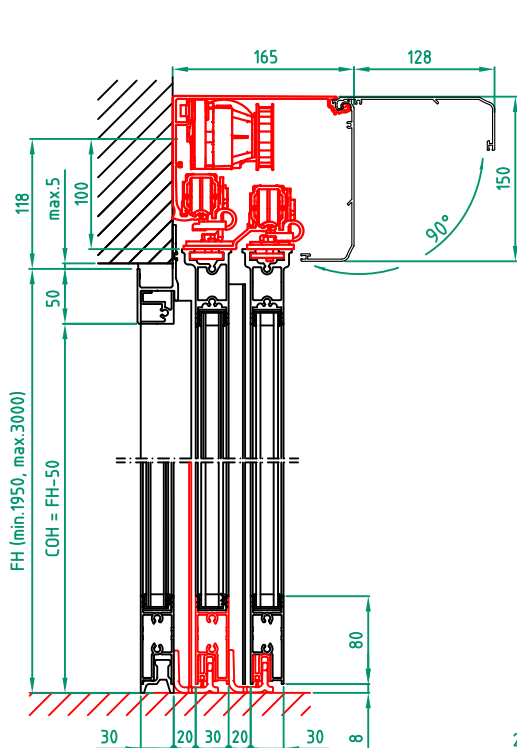

STATE WHEN ORDERING

FW = ..... mm  
 FH = ..... mm  
 X = ..... mm  
 COW = ..... mm  
 COH = ..... mm  
 CL = ..... mm

Surface treatment

- Silver anodized
- Special anodized .....
- RAL .....
- Special powder coating .....

Options see layers:

- Alternative F (concrete/brick)
- Alternative U (aluminium/steel)
- Threshold floor guide, L = FW
- TightSeal (floor level difference max. ± 3 mm)

Glass option see drw. 1009030

Glass code:  
 .....

Limitation

FW x FH = max. 7,8 m<sup>2</sup>

Installation

- Floor heating
- Other .....

Customer: \_\_\_\_\_  
 Door id: \_\_\_\_\_  
 Project No: \_\_\_\_\_

Ref: \_\_\_\_\_  
 Date: \_\_\_\_\_  
 Sign: \_\_\_\_\_

Automatic door system  
 ASSA ABLOY Slim Eco telescopic  
 3 Panel wall mounted opening right, Art. No. 1009392-3PS-15  
 ASSA ABLOY SL520

**ASSA ABLOY**  
 8.0 1009392-EI

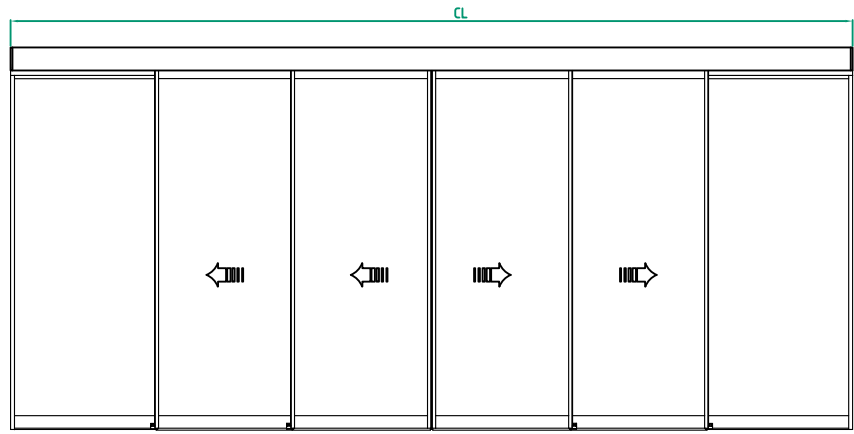
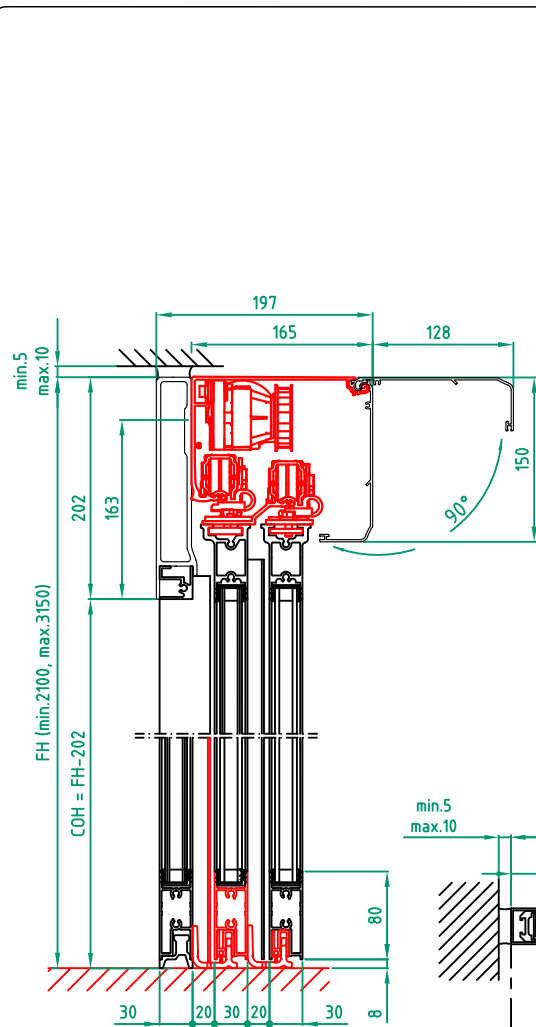

STATE WHEN ORDERING

- FW = ..... mm
- FH = ..... mm
- X = ..... mm
- COW = ..... mm
- COH = ..... mm
- CL = ..... mm

- Surface treatment
- Silver anodized
  - Special anodized .....
  - RAL .....
  - Special powder coating .....

- Options see layers:
- Threshold floor guide, L = FW
  - TightSeal (floor level difference max. ± 3 mm)

Glass option see drw. 1009030  
 Glass code: .....

Limitation  
 FW x FH = max. 16,3 m<sup>2</sup>

- Installation
- Floor heating
  - Other .....

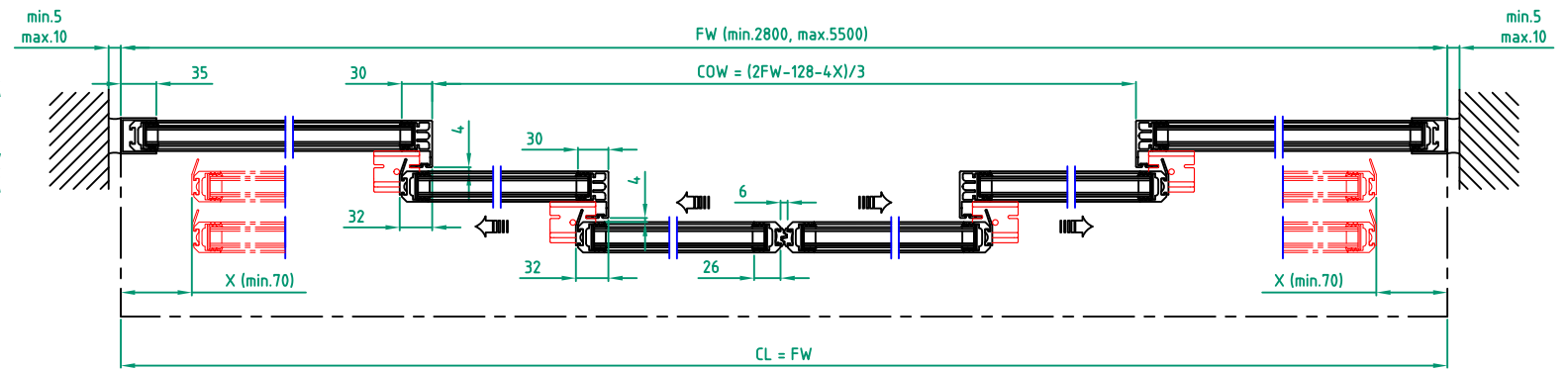

Customer: \_\_\_\_\_

Door id: \_\_\_\_\_

Project No: \_\_\_\_\_

Ref: \_\_\_\_\_

Date: \_\_\_\_\_

Sign: \_\_\_\_\_

Automatic door system  
 ASSA ABLOY Slim Eco telescopic 6 Panel beam mounted  
 Art. No. 1009392-6PB-15  
 ASSA ABLOY SL520

**ASSA ABLOY**

8.0 1009392-EI

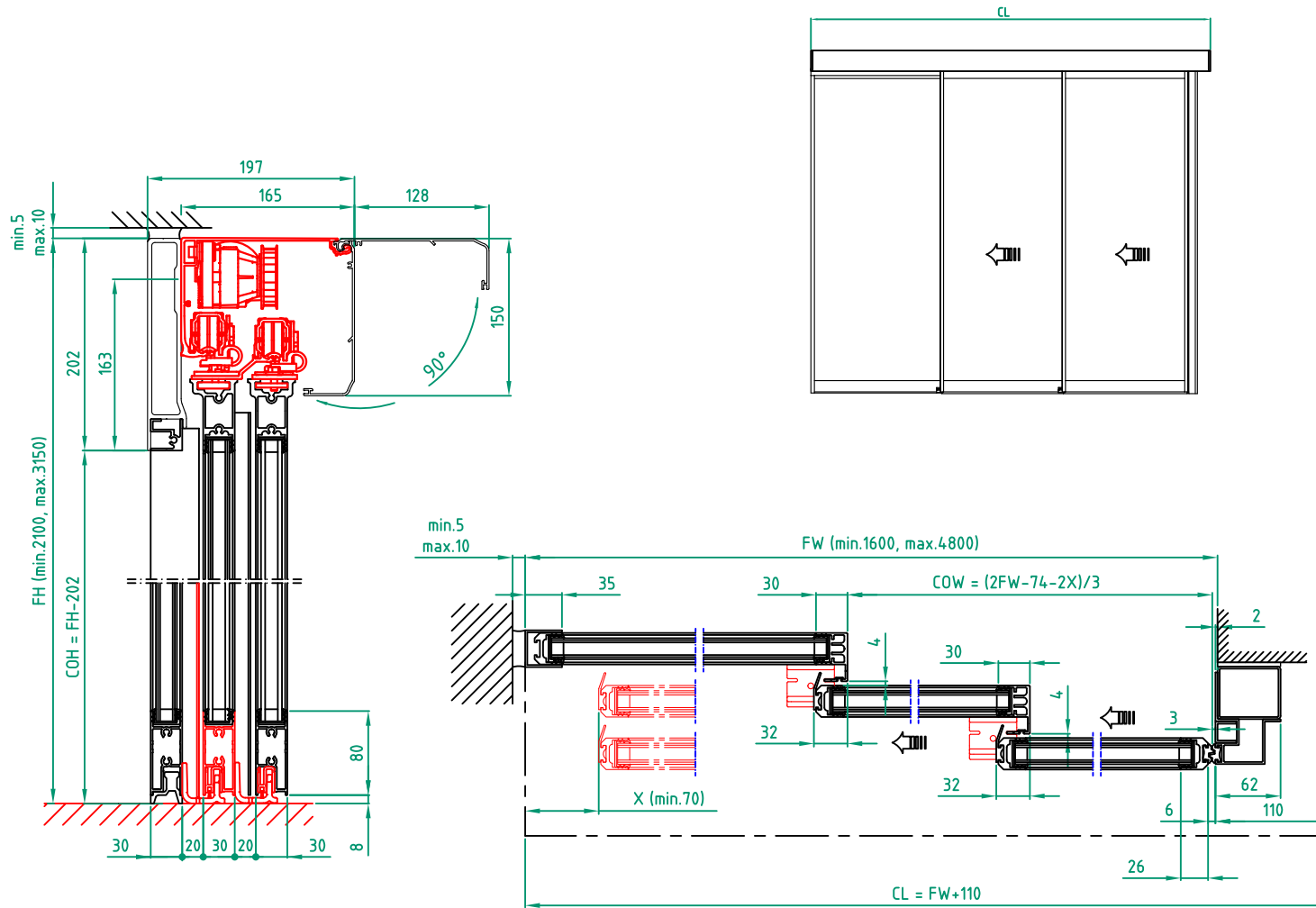

STATE WHEN ORDERING

FW = ..... mm  
 FH = ..... mm  
 X = ..... mm  
 COW = ..... mm  
 COH = ..... mm  
 CL = ..... mm

Surface treatment

Silver anodized  
 Special anodized .....  
 RAL .....  
 Special powder coating .....

Options see layers:

Alternative F (concrete/brick)  
 Alternative U (aluminium/steel)  
 Threshold floor guide, L = FW  
 TightSeal (floor level difference max. ± 3 mm)

Glass option see drw. 1009030

Glass code:  
 .....

Limitation

FW x FH = max. 8,2 m<sup>2</sup>

Installation

Floor heating  
 Other .....

Customer: \_\_\_\_\_  
 Door id: \_\_\_\_\_  
 Project No: \_\_\_\_\_

Ref: \_\_\_\_\_  
 Date: \_\_\_\_\_  
 Sign: \_\_\_\_\_

Automatic door system  
 ASSA ABLOY Slim Eco telescopic  
 3 Panel beam mounted opening left, Art. No. 1009392-3PS-15  
 ASSA ABLOY SL520

**ASSA ABLOY**  
 8.0 1009392-EI



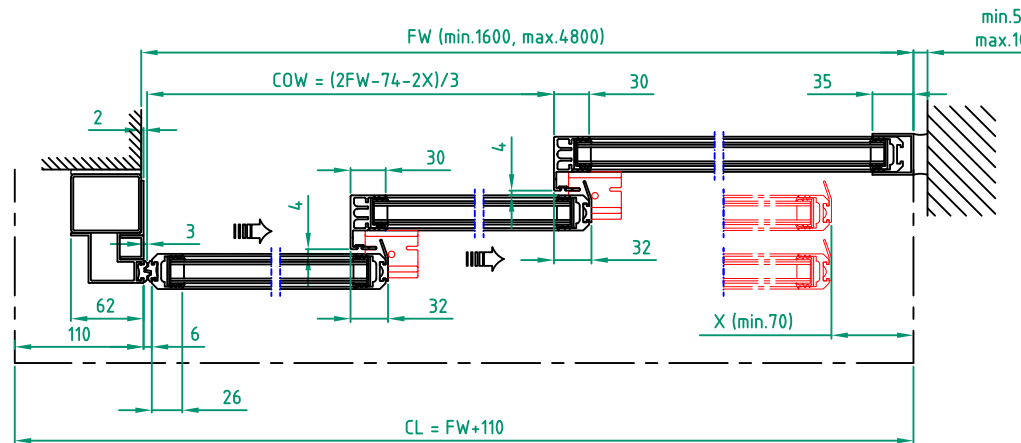
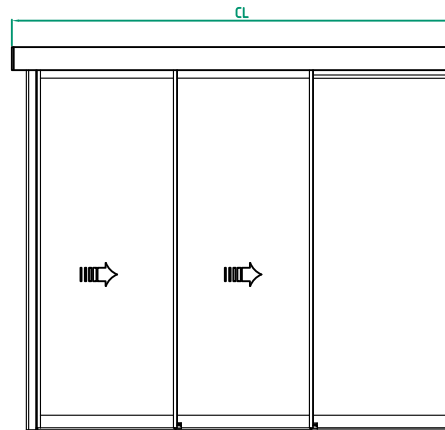
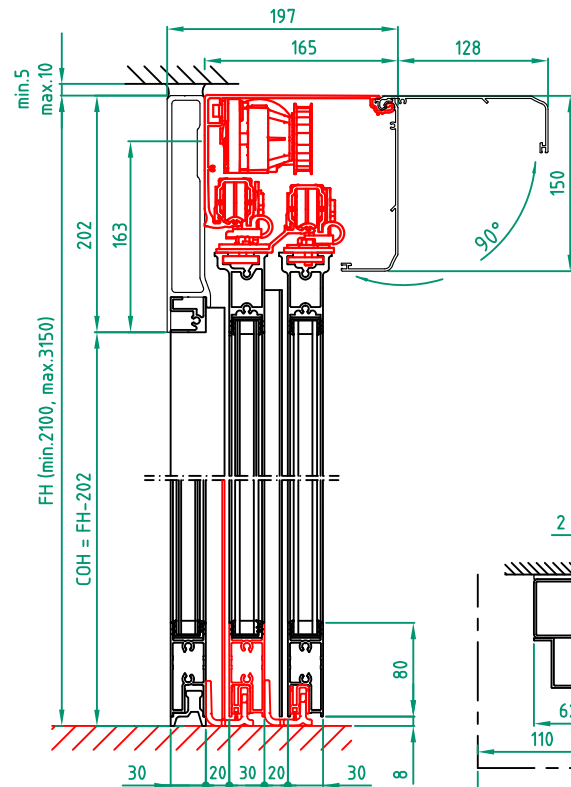

STATE WHEN ORDERING

FW = ..... mm  
 FH = ..... mm  
 X = ..... mm  
 COW = ..... mm  
 COH = ..... mm  
 CL = ..... mm

Surface treatment

- Silver anodized
- Special anodized .....
- RAL .....
- Special powder coating .....

Options see layers:

- Alternative F (concrete/brick)
- Alternative U (aluminium/steel)
- Threshold floor guide, L = FW
- TightSeal (floor level difference max. ± 3 mm)

Glass option see drw. 1009030

Glass code:  
 .....

Limitation

FW x FH = max. 8,2 m<sup>2</sup>

Installation

- Floor heating
- Other .....

Customer:

Ref:

Door id:

Date:

Project No:

Sign:

Automatic door system  
 ASSA ABLOY Slim Eco telescopic  
 3 Panel beam mounted opening right, Art. No. 1009392-3PS-15  
 ASSA ABLOY SL520

**ASSA ABLOY**  
 8.0 1009392-EI